

LOD 65/68 ASSEMBLY INSTRUCTIONS

877-263-5737
www.buzzseating.com

IN THE BOX COMPONENTS

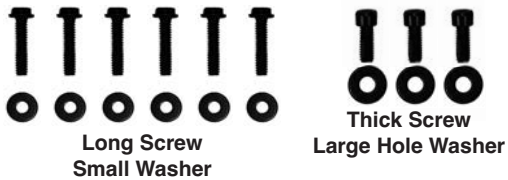
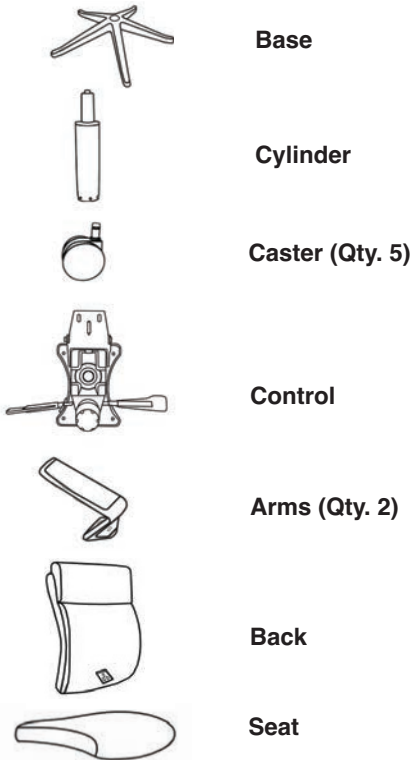

STEP 1 Attaching the Control

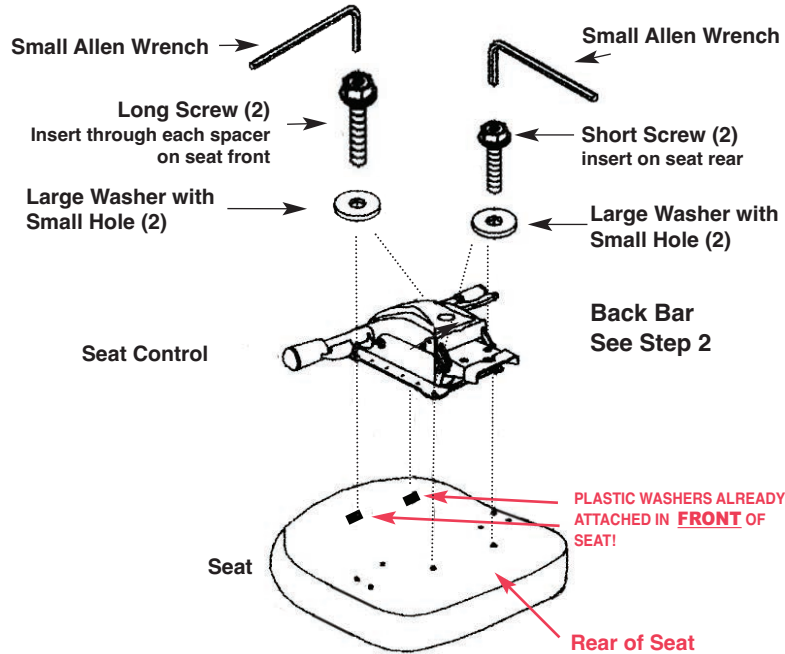

STEP 2 Attaching the Back Bar to the Control

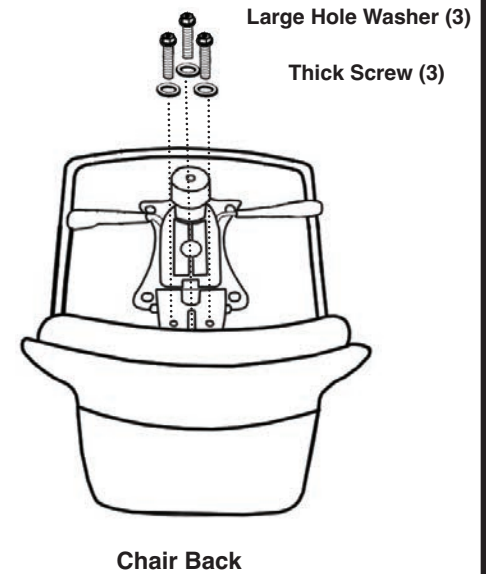

STEP 3 Attaching the Arms

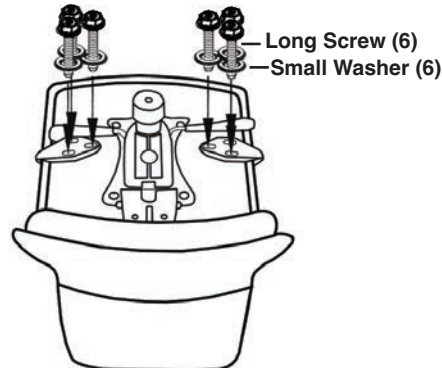

NOTE

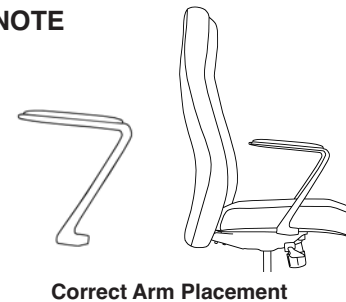

STEP 4

