

DANDY ASSEMBLY INSTRUCTIONS

877-263-5737
www.buzzseating.com

IN THE BOX COMPONENTS

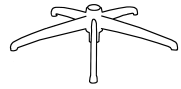

Base



Pneumatic Cylinder



Caster (Qty. 5)



Control



Seat Cushion



Back



Arm (Qty. 2)



Back Support



Head Screw (Qty. 2)



Seat Plate Screw (Qty. 4)



Back Screw (Qty. 3)



Flat Washer (Qty. 2)



Allen Wrench (Qty. 1)

STEP 1

Insert 5 casters into base, push hard until you feel or hear the caster snap into place.

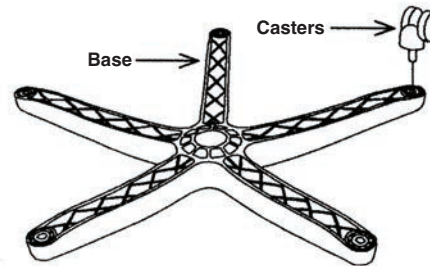

STEP 2

Attach arms to seat cushion using 2 head screws and 2 flat washers for each arm. FULLY TIGHTEN SCREWS USING ALLEN WRENCH.

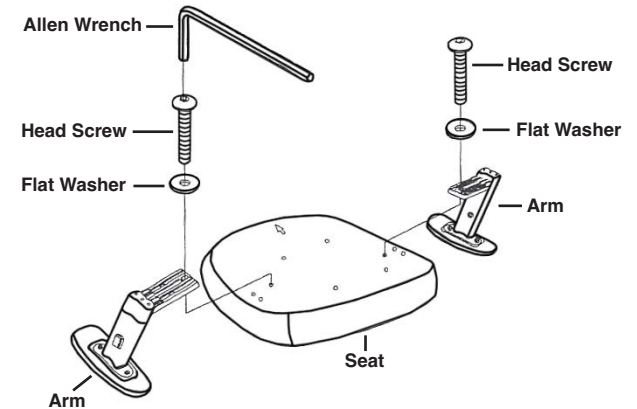

STEP 3

Attach seat control to seat cushion using 2 seat plate screws for the front and 2 seat plate screws for the rear. FULLY TIGHTEN SCREWS USING ALLEN WRENCH.

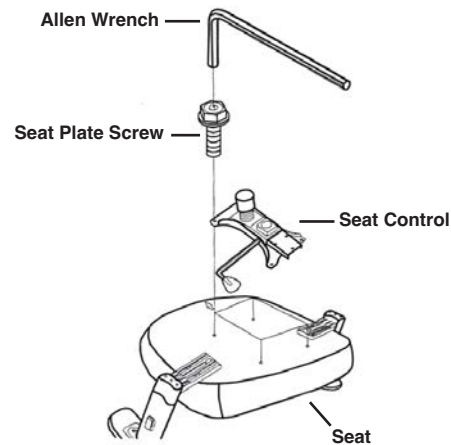

STEP 4

Attach back assembly to assembled seat by inserting back support into rear of seat plate, secure back support using 3 back screws. FULLY TIGHTEN SCREWS USING ALLEN WRENCH.

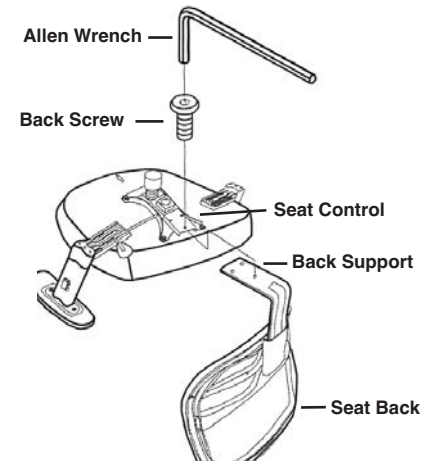

STEP 5

Insert pneumatic cylinder into base, place assembled seat on top of pneumatic cylinder and apply downward pressure.

